

387F Sanitary Ball Valve

3-Piece Tube Full Port
ISO 5211 Direct Mount Pad



**For High Purity
Applications**

Pharmaceutical

Bio-Technology

Fine Chemical

Food & Beverage

Semiconductor

The 387F Series Sanitary Ball Valve

The 387F series ball valve incorporates several of the same innovative design features of our industry leading 337 series high purity valve in a more economical package. The 387 is designed and built to BPE and 3A specifications and meets all FDA, USDA and USP material requirements. The valve incorporates our high-cycle ISO 5211 Direct Mount technology for ease of automation and has a uniform tube full port ID for unobstructed flow and elimination of entrapment areas. The 387 is ideal for automated applications where cost is a major consideration.

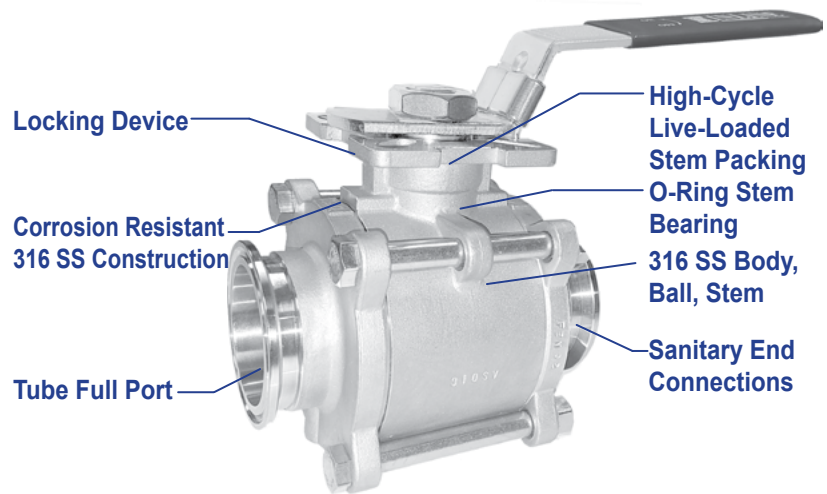

Standard Features and Benefits

- **Tube Full Port Design**
True tube full port construction eliminates pooling of process media and improves flow characteristics for greater efficiency
- **Made of Corrosion-Resistant 316 SS (A351 Gr. CF8M)**
One valve can be used for many service conditions
- **Dual Pattern ISO 5211 Direct Mount Pad**
No bracket or drive coupling needed for automation
Eliminates exposed moving parts for safer work environment
Direct drive eliminates play and improves actuator positioning
Dual pattern pad fits a wide range of actuator sizes
- **High-Cycle, Live-Loaded Stem Packing**
Ensures tight stem seal extending service life
- **O-ring Stem Bearing**
Maintains stem alignment
Reduces packing side-loading and wear
Enhances stem seal
- **Blow-Out-Proof Stem**
Bottom loaded stem prevents removal when valve is in service
- **3-Piece Swing-in-Place Construction**
Easy to repair in service line
- **Locking Device**
Enables plant personnel to secure valve in open or closed position when manually operated
- **BPE Compliant Extended Tube Ends**
- **Investment Cast**
Improves dimensional control and reduces porosity
- **25 Ra Internal Surface Finish**

Options

- **Clamp, Tube Butt Weld, Extended Tube Butt Weld Ends**
- **Polish and Electro-polish to Customer's Specification**
- **Cavity Filled Seats**
- **Full 3A compliance: 3A 68-00 Cavity Filled Construction, Marking and Documentation**
- **Material Test Reports Available Upon Request**

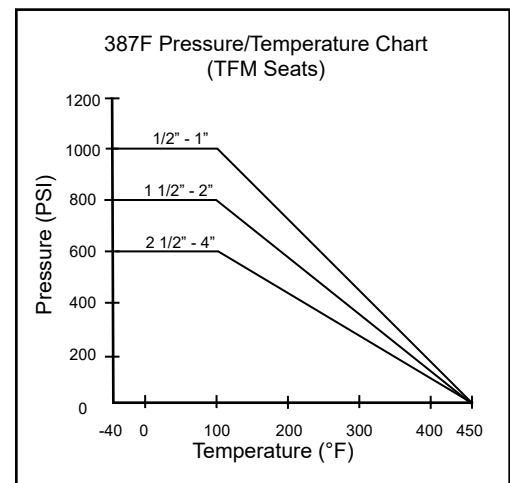

Operating Conditions

- Temperature Range (TFM):
-40°F ~ 450°F
- Maximum Pressure (TFM):
1000 PSI (1/4" - 1")
800 PSI (1 1/2" - 2")
600 PSI (2 1/2" - 4")

Specifications

- Valves designed and tested to ANSI/ASME B16.34 and API 598 and meet ANSI/FCI70-2 Class VI and MSS SP-61 seat leakage requirements
- All materials comply with applicable ASTM material specifications, FDA, USDA and ASME BPE material requirements
- All soft wetted parts comply with FDA CFR Title 21 Part 177

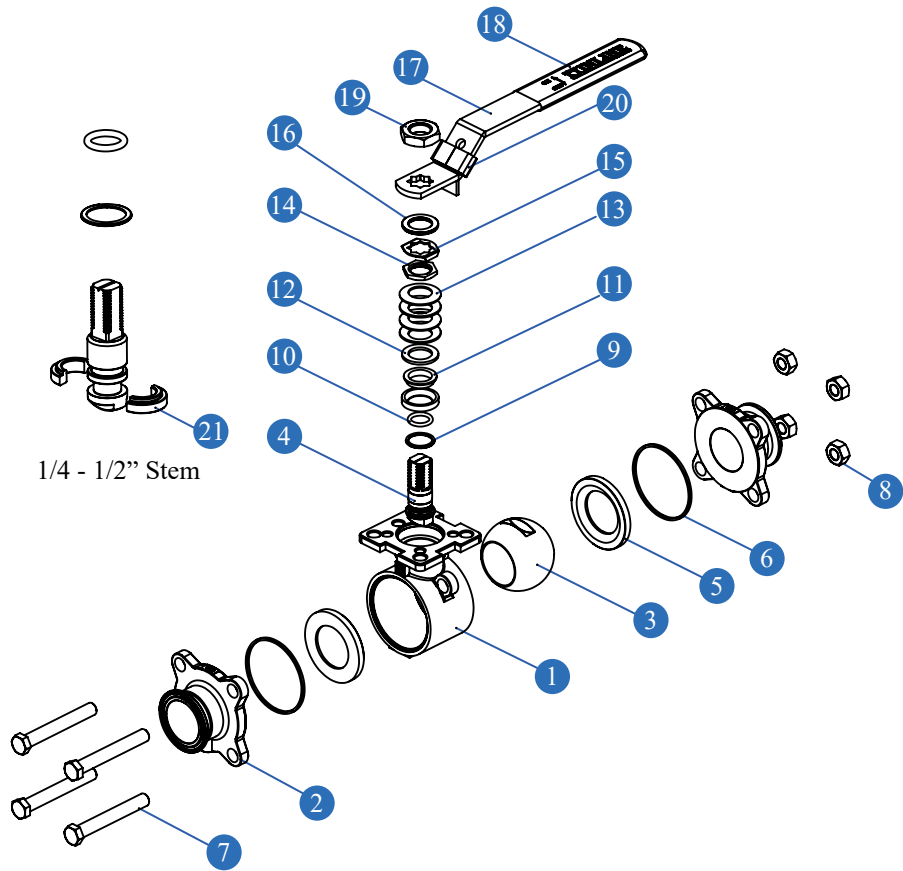

Valve Components			
No.	Part Name	Material	Qty
1	Body	CF8M	1
2	End Cap	CF8M	2
3	Ball	316 SS	1
4	Stem	316 SS	1
5	Seat	TFM	2
6	Body Seal	TFM	2
7	Body Bolt	304 SS	4*
8	Body Nut	304 SS	4*
9	Thrust Washer	PEEK	1
10	Stem O-Ring	VITON 75	1
11	Stem Packing Set	TFM	1
12	Packing Gland	304 SS	1
13	Belleville Washer	301 SS	4
14	Gland Nut	304 SS	1
15	Gland Nut Lock Washer	304 SS	1
16	Stem Spacer	304 SS	1
17	Handle	304 SS	1
18	Handle Cover	Vinyl	1
19	Handle Nut	304 SS	1
20	Handle Lock	304 SS	1
21**	Split Retaining Ring**	316 SS	2

*6 Body Bolts and Body Nuts on 4" Valve
 **1/4 - 1/2" Only

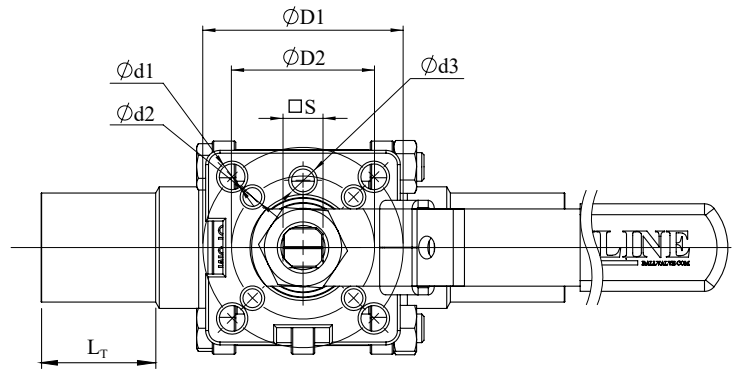
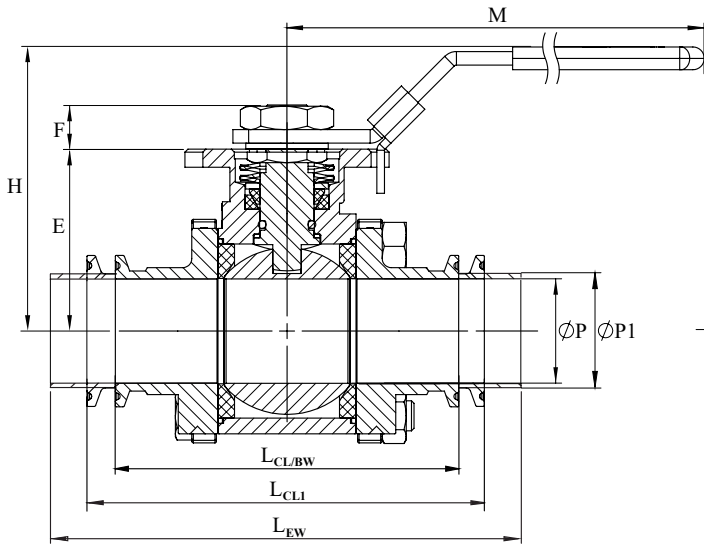

Dimensions (Inches)																						
Size	L _{CL/BW}	L _{EW}	L _{CL1}	L _T	P	P1	M	H	E	F	D1	D2	d1	d2	d3	S	ISO 5211	Torque* (in-lbs)	C _V **	Weight** (lbs)		
1/4"	—	4.54	—	1.57	0.18	0.25	4.9	2.4	1.26	0.35	1.42	-	0.22	-	0.31	0.24	F03	54	0.9	0.8		
3/8"	—	4.54	—	1.57	0.31	0.38	4.9	2.4	1.26	0.35	1.42	-	0.22	-	0.31	0.24	F03	54	3.2	0.8		
1/2"	3.50	4.90	—	1.57	0.37	0.50	4.9	2.4	1.26	0.35	1.42	-	0.22	-	0.31	0.24	F03	54	5.4	0.9		
3/4"	3.50	5.61	4.00	1.57	0.62	0.75	6.1	2.7	1.54	0.35	1.97	1.42	0.26	0.22	0.31	0.35	F03/F05	72	17.5	1.5		
1"	3.50	6.40	4.50	1.57	0.87	1.00	7.6	3.1	1.88	0.41	1.97	1.65	0.26	0.22	0.31	0.43	F04/F05	108	35.7	2.5		
1 1/2"	4.50	7.20	5.50	1.57	1.37	1.50	9.2	3.7	2.39	0.58	2.76	1.97	0.35	0.26	0.31	0.55	F05/F07	282	101	5.3		
2"	5.00	7.60	6.25	1.80	1.87	2.00	9.2	4.1	2.74	0.57	2.76	1.97	0.35	0.26	0.31	0.55	F05/F07	360	201	8.1		
2 1/2"	6.75	10.00	—	1.80	2.37	2.50	13.0	5.1	3.52	0.74	4.02	2.76	0.43	0.35	0.39	0.67	F07/F10	660	330	17.1		
3"	7.76	11.00	—	1.80	2.87	3.00	13.0	5.5	3.89	0.72	4.02	2.76	0.43	0.35	0.39	0.67	F07/F10	716	503	25.5		
4"	9.51	12.00	—	2.01	3.83	4.00	14.8	7.2	5.16	0.94	4.92	4.02	0.53	0.43	0.39	0.87	F10/F12	938	948	46.2		

*Torques provided are measured with standard TFM Seats using 100 psi clean water at ambient temperature
 Please contact us for additional information

C_V value represents flow data to ISA 75.01.01 - 2007
 **C_V value & weights are based on extended BW Ends



Oxygen Cleaning
& Electropolishing



Sanitary Products



Automation
Systems

387F Ordering Information

Example: 2" Full Port Direct Mount Sanitary Ball Valve, 316 SS Body and Trim, TFM Seats and Seals, 316 SS Clamp Ends, 25 Ra Max Mechanical Polish (ID)

Valve Series	Valve Size	Body Material	End Material	Ball Material	Stem Material	Seat	Seal	End Connection	Port Configuration	Ball Configuration	Surface Finish
387F - Full Port	2* 1/4"	6 - A351 Gr. CF8M (316)	6 - A351 Gr. CF8M (316)	6 - 316 SS	6 - 316 SS	M - TFM	M - TFM	CC - Clamp	2 - 2 Way	S - Straight Port	None - 25 Ra Max Mech. Polish
387C - Compression	3* 3/8"		3 - A351 Gr.** CF3M (316L)			T - PTFE	T - PTFE	O - Tube O.D. Butt Weld			SFV1 - 20 Ra Max Mech. Polish
	5 1/2"					J - Cavity Filled TFM	N - 1-Piece TFM Seat/Body Seal	E - Ext.Tube O.D Butt Weld			SFV3 - 30 Ra Max Mech. Polish
	7 3/4"					K - Cavity Filled PTFE		K - Tank Bottom			SFV4 - 15 Ra Max Electropolish
	A 1"					N - 1-Piece TFM Seat/Body Seal		R - I-Line			SFV5 - 20 Ra Max Electropolish
	C 1 1/2"							L - Long Clamp			SFV6 - 25 Ra Max Electropolish
	D 2"							T - NPT (316)			
	E 2 1/2"							P - Compression (316)			
	F 3"							A - ANSI 150# (316)			
	G 4"										

* Available in extended BW and compression ends only

**CF3M (316L) is available in BW ends only

Due to continuous product development, information may change without notice.



INLINE INDUSTRIES, INC.

9056 Garvey Avenue
Rosemead, CA 91770

Tel: (800) 568-8998
(626) 813-6188

Fax: (626) 813-6186

www.ballvalve.com

info@ballvalve.com

Distributed by: